



Efficiently clamp and rotate your bulk box containers.

APPLICATIONS

Bulk Box Handlers are used to handle produce, piece parts, etc., where a box attached to a pallet requires support of multipurpose arms for rotating and dumping.

FEATURES

- Easy mounting and removal

*Bulk box
inverting and
dumping versatility.*



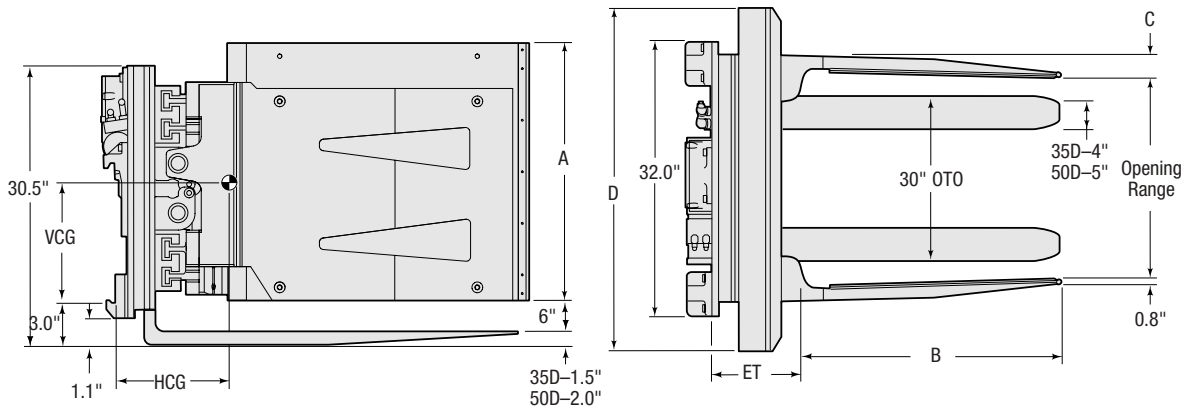

Capacity @ 24" (600 mm) Load Center		Opening Range (ITI)	Catalog Order No.	Mtg. Class	Mtg. Angle	Arm Height	Usable Fork/Arm Length	Weight		Effective Thickness	Horizontal Ctr. of Gravity	Vertical Ctr. of Gravity	Arm Thickness	Overall Width
lbs	kg							lbs	kg					
3,500	1,590	21.7"-70.7"	35D-BBH	II	0°	24"	42"	1,930	876	12.4"	15.8"	13.1"	2.2"	37"
5,000	2,270	23.1"-70.9"	50D-BBH	III	0°	36"	42"	2,580	1,171	13.5"	16.8"	14.0"	2.5"	40"

- ▶ Bulk Box Handlers are built to order. When ordering please specify:
 - Arm length
 - Arm height
 - Usable fork length
 - Fork spread
 - Opening range
 - Distance between fork and arm
- ▶ Rotator speed : 5.7 RPM @ 10 GPM.
Rotator Torque: 55,000 Inch-lbs@ 2,000 PSI.
- ▶ Optional body bumper available

Installation Kit

Catalog Order No.
672442