



For efficient, economical bale handling.

Efficiently and economically handle nearly any type of baled product.

APPLICATIONS

Cascade bale clamps can efficiently and economically handle nearly any type of baled product including cotton, and synthetic textile bales, corrugated, newsprint, rag, hay, metal and other scrap bales.

FEATURES

- Proven, durable arm and aluminum frame construction ensuring long, useful life of the clamp
- Superior arm-slide material and design for extended bearing life
- Low profile frame for visibility over the clamp
- Thin arm profiles for handling in between tightly spaced loads
- Regenerative hydraulic valving for optimal arm speed
- Revolving models available for load inverting

OPTIONS

- Custom opening ranges
- Custom arm sizes
- Custom arm ribbing
- Various mounting classes available
- Quick-change lower hooks
- Load backrests



NON-SIDESHIFTING

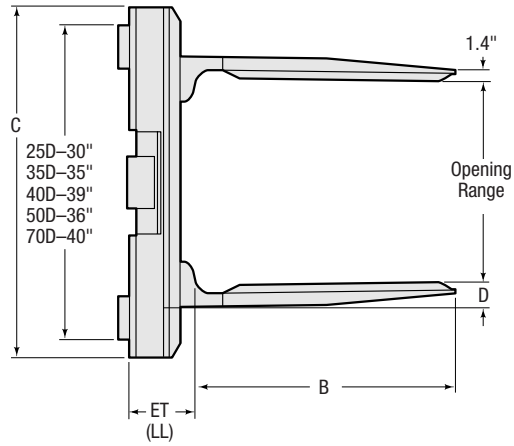
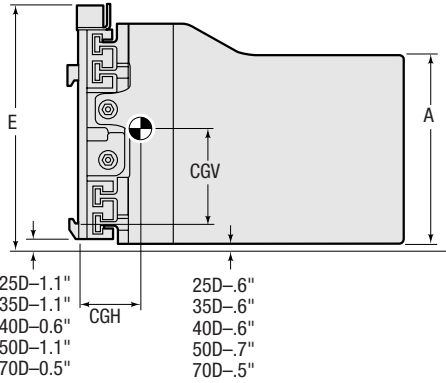

40D Cotton Bale Arm Facing Options

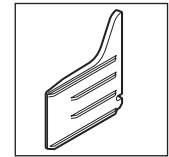

40D Standard Ribbs

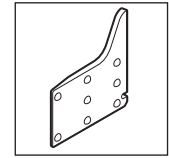

Button Facing

Capacity Lbs. @ 24" Load Center	Opening Range (ITR)	Catalog Order No.	Mounting Class	Arm Height A	Arm Length B	Weight (Lbs.)	Effective Thickness ET	Horizontal Center of Gravity CGH	Vertical Center of Gravity CGV	Overall Width C	Arm Thickness D	Overall Height E
2,500	17.8"-63.4"	25D-BCB-51A	II	15.6"	27"	670	6.5"	8.0"	8.4"	36"	2.6"	25.2"
2,500	17.8"-63.4"	25D-BCB-52A	II	15.6"	31"	715	6.5"	9.6"	8.4"	36"	2.6"	25.2"
2,500	17.6"-63.2"	25D-BCB-54A	II	15.6"	36"	780	6.5"	12.2"	8.4"	36"	2.6"	25.2"
2,500	17.4"-63.0"	25D-BCB-53A	II	15.6"	39"	790	6.5"	12.6"	8.4"	36"	2.6"	25.2"
3,500	17.8"-68.4"	35D-BCB-51A	II	16.4"	27"	770	6.8"	8.0"	8.7"	41"	2.8"	26.1"
3,500	17.8"-68.4"	35D-BCB-52A	II	16.4"	31"	830	6.8"	9.4"	8.7"	41"	2.8"	26.1"
3,500	17.6"-68.2"	35D-BCB-55A	II	16.4"	36"	920	6.8"	12.1"	8.7"	41"	2.8"	26.1"
3,500	17.5"-68.1"	35D-BCB-53A	II	16.4"	39"	930	6.8"	12.4"	8.7"	41"	2.8"	26.1"
3,500	17.4"-68.0"	35D-BCB-54A	II	16.4"	47"	1,025	6.8"	15.8"	8.7"	41"	2.8"	26.1"
4,000	19.3"-91.8"	40D-BCB-55A ①②	II	18.0"	28"	1,285	5.6"	7.1"	10.1"	63"	2.7"	28.7"
4,000	37.6"-118.4"	40D-BCB-54A ①②	II	18.0"	28"	1,370	5.6"	6.7"	10.1"	68"	2.7"	28.7"
5,000	22.4"-75.4"	50D-BCB-51A	II	18.0"	27"	1,020	7.4"	7.9"	10.0"	40"	3.0"	28.7"
5,000	22.4"-75.4"	50D-BCB-51B	III	18.2"	27"	1,065	7.7"	7.9"	10.0"	40"	3.0"	28.7"
5,000	22.4"-75.4"	50D-BCB-52A	II	18.2"	31"	1,095	7.4"	9.3"	10.0"	40"	3.0"	28.7"
5,000	22.4"-75.4"	50D-BCB-52B	III	18.2"	31"	1,140	7.7"	9.3"	10.0"	40"	3.0"	28.7"
5,000	22.2"-75.2"	50D-BCB-55A	II	18.2"	36"	1,185	7.4"	12.1"	10.0"	40"	3.0"	28.7"
5,000	22.2"-75.2"	50D-BCB-55B	III	18.2"	36"	1,230	7.7"	12.0"	10.0"	40"	3.0"	28.7"
5,000	22.2"-75.2"	50D-BCB-53A	II	18.2"	39"	1,225	7.4"	12.4"	10.0"	40"	3.0"	28.7"
5,000	22.2"-75.2"	50D-BCB-53B	III	18.2"	39"	1,275	7.7"	12.3"	10.0"	40"	3.0"	28.7"
5,000	22.0"-75.0"	50D-BCB-54A	II	18.2"	47"	1,375	7.4"	15.6"	10.0"	40"	3.0"	28.7"
5,000	22.0"-75.0"	50D-BCB-54B	III	18.2"	47"	1,410	7.7"	15.4"	10.0"	40"	3.0"	28.7"
7,000	22.6"-83.0"	70D-BCB-51B ②	III	18.0"	48"	2,070	7.0"	14.6"	14.2"	48"	3.2"	32.2"
7,000	22.6"-83.0"	70D-BCB-51C ②	IV	18.0"	48"	2,070	7.0"	14.6"	12.2"	48"	3.2"	32.2"
7,000	22.6"-83.0"	70D-BCB-52B ②	III	18.0"	54"	2,180	7.0"	16.6"	14.0"	48"	3.2"	32.2"
7,000	22.6"-83.0"	70D-BCB-52C ②	IV	18.0"	54"	2,180	7.0"	16.6"	12.0"	48"	3.2"	32.2"
7,000	22.6"-83.0"	70D-BCB-53B ②	III	18.0"	60"	2,300	7.0"	18.6"	13.8"	48"	3.2"	32.2"
7,000	22.6"-83.0"	70D-BCB-53C ②	IV	18.0"	60"	2,300	7.0"	18.6"	11.8"	48"	3.2"	32.2"

① Premier model for cotton industry. Button facing available.

② Integral arms.

INSTALLATION KITS

Catalog Order No.
659245

HYDRAULIC FLOW AND PRESSURE

Model	Minimum	Recommended	Maximum	Max. Pressure
25D BCB	4 GPM	5.5 GPM	5.5 GPM	2,300 PSI
35D BCB	4 GPM	7 GPM	7 GPM	2,300 PSI
50D BCB	4 GPM	10 GPM	10 GPM	2,300 PSI
70D BCB	7 GPM	12 GPM	15 GPM	2,300 PSI

MOUNTING CLASS INFORMATION

Mounting Class	Truck Capacity
II	2,000-5,500 lbs.
III	6,000-10,000 lbs.
IV	10,001-17,500 lbs.

HYDRAULIC FUNCTIONS

Hydraulic Functions	Truck Auxiliary Valves Required
1	1

SIDESHIFTING

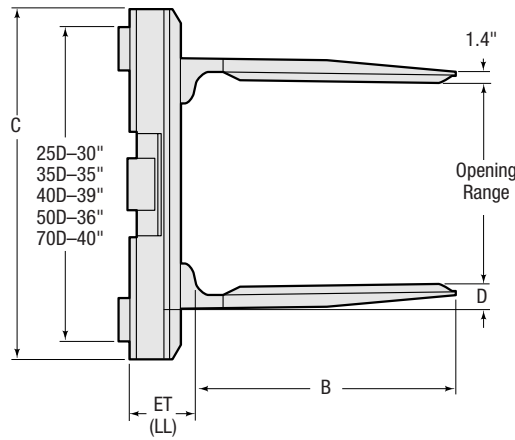
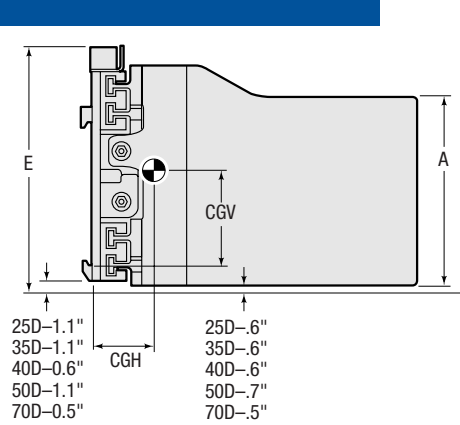

40D Cotton Bale Arm Facing Options

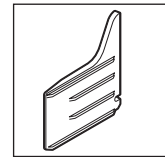

40D Standard Rib

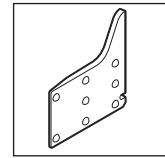

Button Facing

Capacity Lbs. @ 24" Load Center	Opening Range (IT)	Catalog Order No.	Mounting Class	Arm Height A	Arm Length B	Weight (Lbs.)	Effective Thickness ET	Horizontal Center of Gravity CGH	Vertical Center of Gravity CGV	Overall Width C	Arm Thickness D	Overall Height E
2,500	17.8"-63.4"	25D-BCS-61A	II	15.6"	27"	670	6.5"	8.0"	8.4"	36"	2.6"	25.2"
2,500	17.8"-63.4"	25D-BCS-62A	II	15.6"	31"	715	6.5"	9.6"	8.4"	36"	2.6"	25.2"
2,500	17.6"-63.2"	25D-BCS-64A	II	15.6"	36"	780	6.5"	12.2"	8.4"	36"	2.6"	25.2"
2,500	17.4"-63.0"	25D-BCS-63A	II	15.6"	39"	790	6.5"	12.6"	8.4"	36"	2.6"	25.2"
3,500	17.8"-68.4"	35D-BCS-61A	II	16.4"	27"	770	6.8"	8.0"	8.7"	41"	2.8"	26.1"
3,500	17.8"-68.4"	35D-BCS-62A	II	16.4"	31"	830	6.8"	9.4"	8.7"	41"	2.8"	26.1"
3,500	17.6"-68.2"	35D-BCS-65A	II	16.4"	36"	920	6.8"	12.1"	8.7"	41"	2.8"	26.1"
3,500	17.5"-68.1"	35D-BCS-63A	II	16.4"	39"	930	6.8"	12.4"	8.7"	41"	2.8"	26.1"
3,500	17.4"-68.0"	35D-BCS-64A	II	16.4"	47"	1,025	6.8"	15.8"	8.7"	41"	2.8"	26.1"
4,000	19.3"-91.8"	40D-BCS-65A ①②	II	18.0"	28"	1,285	5.6"	7.1"	10.1"	63"	2.7"	28.7"
4,000	37.6"-118.4"	40D-BCS-64A ①②	II	18.0"	28"	1,370	5.6"	6.7"	10.1"	68"	2.7"	28.7"
5,000	22.4"-75.4"	50D-BCS-61A	II	18.0"	27"	1,020	7.4"	7.9"	10.0"	40"	3.0"	28.7"
5,000	22.4"-75.4"	50D-BCS-61B	II	18.2"	27"	1,065	7.7"	7.9"	10.0"	40"	3.0"	28.7"
5,000	22.4"-75.4"	50D-BCS-62A	II	18.2"	31"	1,095	7.4"	9.3"	10.0"	40"	3.0"	28.7"
5,000	22.4"-75.4"	50D-BCS-62B	III	18.2"	31"	1,140	7.7"	9.3"	10.0"	40"	3.0"	28.7"
5,000	22.2"-75.2"	50D-BCS-65A	II	18.2"	36"	1,185	7.4"	12.1"	10.0"	40"	3.0"	28.7"
5,000	22.2"-75.2"	50D-BCS-65B	III	18.2"	36"	1,230	7.7"	12.0"	10.0"	40"	3.0"	28.7"
5,000	22.2"-75.2"	50D-BCS-63A	II	18.2"	39"	1,225	7.4"	12.4"	10.0"	40"	3.0"	28.7"
5,000	22.2"-75.2"	50D-BCS-63B	III	18.2"	39"	1,275	7.7"	12.3"	10.0"	40"	3.0"	28.7"
5,000	22.0"-75.0"	50D-BCS-64A	II	18.2"	47"	1,375	7.4"	15.6"	10.0"	40"	3.0"	28.7"
5,000	22.0"-75.0"	50D-BCS-64B	III	18.2"	47"	1,410	7.7"	15.4"	10.0"	40"	3.0"	28.7"
7,000	22.6"-83.0"	70D-BCS-61B ②	III	18.0"	48"	2,070	7.0"	14.6"	14.2"	48"	3.2"	32.2"
7,000	22.6"-83.0"	70D-BCS-61C ②	IV	18.0"	48"	2,070	7.0"	14.6"	12.2"	48"	3.2"	32.2"
7,000	22.6"-83.0"	70D-BCS-62B ②	III	18.0"	54"	2,180	7.0"	16.6"	14.0"	48"	3.2"	32.2"
7,000	22.6"-83.0"	70D-BCS-62C ②	IV	18.0"	54"	2,180	7.0"	16.6"	12.0"	48"	3.2"	32.2"
7,000	22.6"-83.0"	70D-BCS-63B ②	III	18.0"	60"	2,300	7.0"	18.6"	13.8"	48"	3.2"	32.2"
7,000	22.6"-83.0"	70D-BCS-63C ②	IV	18.0"	60"	2,300	7.0"	18.6"	11.8"	48"	3.2"	32.2"

① Premier model for cotton industry. Button facing available.

② Integral arms.

INSTALLATION KITS

Catalog Order No.
659249

HYDRAULIC FLOW AND PRESSURE

Model	Minimum	Recommended	Maximum	Max. Pressure
25D BCS	4 GPM	5.5 GPM	5.5 GPM	2,300 PSI
35D BCS	4 GPM	7 GPM	7 GPM	2,300 PSI
50D BCS	4 GPM	10 GPM	10 GPM	2,300 PSI
70D BCS	7 GPM	12 GPM	15 GPM	2,300 PSI

MOUNTING CLASS INFORMATION

Mounting Class	Truck Capacity
II	2,000-5,500 lbs.
III	6,000-10,000 lbs.
IV	10,001-17,500 lbs.

HYDRAULIC FUNCTIONS

Hydraulic Functions	Truck Auxiliary Valves Required
2	2

35D-50D REVOLVING

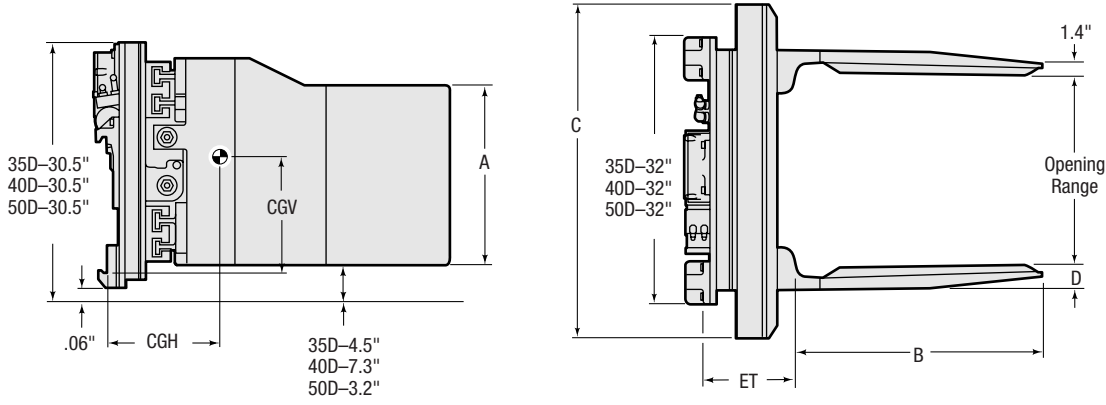

Capacity Lbs. @ 24" Load Center	Opening Range (ITI)	Catalog Order No.	Mounting Class	Arm Height A	Arm Length B	Weight (Lbs.)	Effective Thickness ET	Horizontal Center of Gravity CGH	Vertical Center of Gravity CGV	Mounting Angle ③	Overall Width C	Arm Thickness D
3,500	17.8"-68.4"	35D-BCR-71A	II	16.4"	27"	1,250	10.5"	8.5"	13.2"	0°	41"	2.8"
3,500	17.8"-68.4"	35D-BCR-71F	II	16.4"	27"	1,250	9.5"	7.6"	13.2"	4°	41"	2.8"
3,500	17.8"-68.4"	35D-BCR-72A	II	16.4"	31"	1,310	10.5"	9.5"	13.2"	0°	41"	2.8"
3,500	17.8"-68.4"	35D-BCR-72F	II	16.4"	31"	1,310	9.5"	8.6"	13.2"	4°	41"	2.8"
3,500	17.5"-68.2"	35D-BCR-75A	II	16.4"	36"	1,410	10.5"	11.6"	13.2"	0°	41"	2.8"
3,500	17.5"-68.2"	35D-BCR-75F	II	16.4"	36"	1,410	9.5"	10.7"	13.2"	4°	41"	2.8"
3,500	17.5"-68.1"	35D-BCR-73A	II	16.4"	39"	1,410	10.5"	11.8"	13.2"	0°	41"	2.8"
3,500	17.5"-68.1"	35D-BCR-73F	II	16.4"	39"	1,410	9.5"	10.9"	13.2"	4°	41"	2.8"
3,500	17.4"-68.0"	35D-BCR-74A	II	16.4"	47"	1,505	10.5"	14.5"	13.2"	0°	41"	2.8"
3,500	17.4"-68.0"	35D-BCR-74F	II	16.4"	47"	1,505	9.5"	13.6"	13.2"	4°	41"	2.8"
4,000	19.3"-91.8"	40D-BCR-75A ①②	II	18.0"	28"	1,755	9.3"	8.6"	13.2"	0°	63"	2.7"
4,000	19.3"-91.8"	40D-BCR-75F ①②	II	18.0"	28"	1,755	8.3"	7.7"	13.2"	4°	63"	2.7"
4,000	19.3"-91.8"	40D-BCR-75B ①②	III	18.0"	28"	1,790	11.0"	10.1"	13.2"	0°	63"	2.7"
4,000	19.3"-91.8"	40D-BCR-75G ①②	III	18.0"	28"	1,790	9.8"	8.9"	13.2"	4°	63"	2.7"
5,000	22.4"-75.4"	50D-BCR-71A	II	18.2"	27"	1,485	11.1"	9.3"	13.2"	0°	40"	3.0"
5,000	22.4"-75.4"	50D-BCR-71F	II	18.2"	27"	1,485	10.1"	8.4"	13.2"	4°	40"	3.0"
5,000	22.4"-75.4"	50D-BCR-71B	III	18.2"	27"	1,520	12.8"	10.8"	13.2"	0°	40"	3.0"
5,000	22.4"-75.4"	50D-BCR-71G	III	18.2"	27"	1,520	11.6"	9.6"	13.2"	4°	40"	3.0"
5,000	22.4"-75.4"	50D-BCR-72A	II	18.2"	31"	1,560	11.1"	10.4"	13.2"	0°	40"	3.0"
5,000	22.4"-75.4"	50D-BCR-72F	II	18.2"	31"	1,560	10.1"	9.6"	13.2"	4°	40"	3.0"
5,000	22.4"-75.4"	50D-BCR-72B	III	18.2"	31"	1,600	12.8"	11.9"	13.2"	0°	40"	3.0"
5,000	22.4"-75.4"	50D-BCR-72G	III	18.2"	31"	1,600	11.6"	10.7"	13.2"	4°	40"	3.0"
5,000	22.2"-75.2"	50D-BCR-75A	II	18.2"	36"	1,690	11.1"	12.7"	13.2"	0°	40"	3.0"
5,000	22.2"-75.2"	50D-BCR-75F	II	18.2"	36"	1,690	10.1"	11.9"	13.2"	4°	40"	3.0"
5,000	22.2"-75.2"	50D-BCR-75B	III	18.2"	36"	1,725	12.8"	14.2"	13.2"	0°	40"	3.0"
5,000	22.2"-75.2"	50D-BCR-75G	III	18.2"	36"	1,725	11.6"	13.0"	13.2"	4°	40"	3.0"
5,000	22.1"-75.1"	50D-BCR-73A	II	18.2"	39"	1,700	11.1"	12.9"	13.2"	0°	40"	3.0"
5,000	22.1"-75.1"	50D-BCR-73F	II	18.2"	39"	1,700	10.1"	12.1"	13.2"	4°	40"	3.0"
5,000	22.1"-75.1"	50D-BCR-73B	III	18.2"	39"	1,735	12.8"	14.4"	13.2"	0°	40"	3.0"
5,000	22.1"-75.1"	50D-BCR-73G	III	18.2"	39"	1,735	11.6"	13.2"	13.2"	4°	40"	3.0"
5,000	22.0"-75.0"	50D-BCR-74A	II	18.2"	47"	1,840	11.1"	15.6"	13.2"	0°	40"	3.0"
5,000	22.0"-75.0"	50D-BCR-74F	II	18.2"	47"	1,840	10.1"	14.7"	13.2"	4°	40"	3.0"
5,000	22.0"-75.0"	50D-BCR-74B	III	18.2"	47"	1,880	12.8"	17.0"	13.2"	0°	40"	3.0"
5,000	22.0"-75.0"	50D-BCR-74G	III	18.2"	47"	1,880	11.6"	15.8"	13.2"	4°	40"	3.0"
5,000	22.0"-75.0"	50D-BCR-74A	II	18.2"	47"	1,840	9.3"	15.6"	13.2"	0°	40"	3.0"
5,000	22.0"-75.0"	50D-BCR-74F	II	18.2"	47"	1,840	8.3"	14.7"	13.2"	4°	40"	3.0"
5,000	22.0"-75.0"	50D-BCR-74B	III	18.2"	47"	1,880	11.0"	17.0"	13.2"	0°	40"	3.0"
5,000	22.0"-75.0"	50D-BCR-74G	III	18.2"	47"	1,880	9.8"	15.8"	13.2"	4°	40"	3.0"

① Premier model for cotton industry. Button facing available.

② Integral arms.

③ Vertical mount (0° mounting angle) is recommended for lift heights exceeding 180".

► Rotator speed: 5.2 RPM @ 15 GPM.
Rotator torque: 65,000 Inch-Lbs. @ 2,000 PSI.

70D REVOLVING

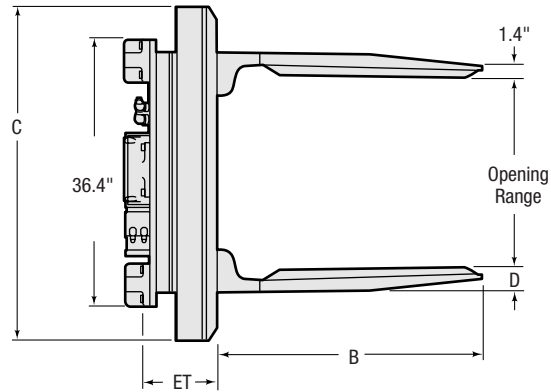
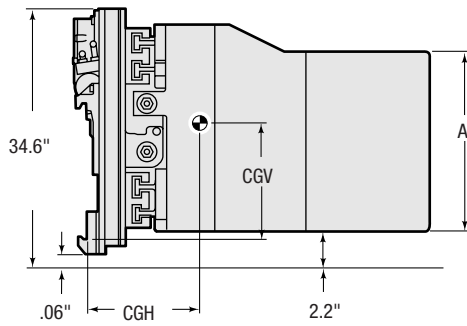

Capacity Lbs. @ 24" Load Center	Opening Range (ITI)	Catalog Order No.	Mounting Class	Mounting Angle ②	Arm Height A	Arm Length B	Weight (Lbs.)	Effective Thickness ET	Horizontal Center of Gravity CGH	Vertical Center of Gravity CGV	Overall Width C	Arm Thickness D
7,000	22.6"-83.0"	70D-BCR-71B ①	III	0°	18.0"	48"	2,660	10.7"	14.8"	13.1"	48"	3.2"
7,000	22.6"-83.0"	70D-BCR-71G ①	III	4°	18.0"	48"	2,640	9.4"	13.6"	13.2"	48"	3.2"
7,000	22.6"-83.0"	70D-BCR-71C ①	IV	0°	18.0"	48"	2,780	13.0"	16.5"	10.5"	48"	3.2"
7,000	22.6"-83.0"	70D-BCR-71H ①	IV	4°	18.0"	48"	2,740	11.2"	15.0"	10.7"	48"	3.2"
7,000	22.6"-83.0"	70D-BCR-72B ①	III	0°	18.0"	54"	2,770	10.7"	16.5"	12.9"	48"	3.2"
7,000	22.6"-83.0"	70D-BCR-72G ①	III	4°	18.0"	54"	2,750	9.4"	15.3"	13.0"	48"	3.2"
7,000	22.6"-83.0"	70D-BCR-72C ①	IV	0°	18.0"	54"	2,890	13.0"	18.2"	10.3"	48"	3.2"
7,000	22.6"-83.0"	70D-BCR-72H ①	IV	4°	18.0"	54"	2,850	11.2"	16.7"	10.5"	48"	3.2"
7,000	22.6"-83.0"	70D-BCR-73B ①	III	0°	18.0"	60"	2,890	10.7"	18.3"	12.7"	48"	3.2"
7,000	22.6"-83.0"	70D-BCR-73G ①	III	4°	18.0"	60"	2,870	9.4"	17.1"	12.8"	48"	3.2"
7,000	22.6"-83.0"	70D-BCR-73C ①	IV	0°	18.0"	60"	3,010	13.0"	20.0"	10.1"	48"	3.2"
7,000	22.6"-83.0"	70D-BCR-73H ①	IV	4°	18.0"	60"	2,970	11.2"	18.5"	10.3"	48"	3.2"

- ① Integral arms.
- ② Vertical mount (0° mounting angle) is recommended for lift heights exceeding 180".

▶ Rotator speed: 4.5 RPM @ 15 GPM.
Rotator torque: 65,000 Inch-Lbs. @ 2,000 PSI.

INSTALLATION KITS

Model	Catalog Order No.
Revolving	672442

HYDRAULIC FLOW AND PRESSURE

Model	Minimum	Recommended	Maximum	Max. Pressure
35D & 50D BCR	5 GPM	10 GPM	15 GPM	2,300 PSI
70D BCR	7 GPM	12 GPM	15 GPM	2,300 PSI

MOUNTING CLASS INFORMATION

Mounting Class	Truck Capacity
II	2,000-5,500 lbs.
III	6,000-10,000 lbs.
IV	10,001-17,500 lbs.

HYDRAULIC FUNCTIONS

Model	Hydraulic Functions	Truck Auxiliary Valves Required
Revolving	2	2

Narrow Closing Range

For narrower than standard closing ranges, add to list price of standard clamp as follows:

Model	Frame Width	Opening Range
25D	34"	6.5"-41.7"
35D	37"	6.0"-45.2"
50D	40"	6.3"-47.3"
70D	48"	8.2"-60.0"

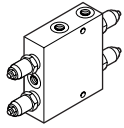

Hydraulic Flow Control Valve

Allows attachment operating speed to be adjusted for maximum efficiency by regulating hydraulic flow from truck auxiliary system. Also prevents overheating and excessive pressure drop. Requires a direct line to tank.

Flow Required	Catalog Order No.
3.5 GPM	207496
5 GPM	207497
7 GPM	207498
10 GPM	207499
12 GPM	207500

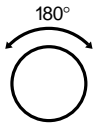

180° Rotation Stop Group (Factory Installed)

A 180° Rotation Stop Group is used when the load is repeatedly rotated in the same 180° cycle and a permanent rotation stop point is desired. A hydraulic shut-off decreases rotation speed just prior to the mechanical stop point.

Catalog Order No.

Consult Cascade

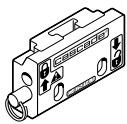

Quick-Disconnect Mounting Kits

Mounting Class
II
III
IV

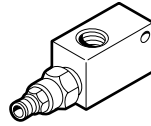

Single Pressure Setting Relief Valve

Limits hydraulic pressure in one line to attachment. two valves required per auxiliary function.

Catalog Order No.

661674 (2-20 GPM)

685968 (20-50 GPM)

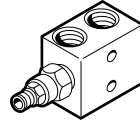

Bi-Directional Pressure Relief Valve

Allows single valve to be used for each auxiliary function to limit hydraulic pressure to attachment.

Catalog Order No.

677379



Pressure Gauge

Catalog Order No.

664158

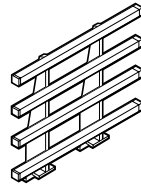

Load Backrest for Non-Sideshifting & Sideshifting Clamps

Model	Dimensions H x W ①	Weight (lbs.)	Catalog Order No.
Bolt-On ②			
25D	48" x 34"	55	669765
35D	48" x 37"	55	686417
50D	48" x 40"	53	669767
Weld-On ③			
70D	48" x 37"	55	686417

- ① Height measured from ground to top of load backrest
- ② Field or factory installed.
- ③ Factory installed only.