



Fork positioning for high capacity warehousing, manufacturing and distribution

APPLICATIONS

The class IV sideshifting fork positioners allow drivers to position forks accurately for a variety of pallet configurations, without ever leaving their seat. These new generation fork positioners are easy to install, have excellent lost load, and can handle an array of challenging applications.

Recommended for logistic operations in distribution, warehouse and manufacturing applications, these class IV fork positioners are very rugged and compact. They have excellent visibility both over, and through the frames, allowing the operator to quickly, accurately, and easily position the forks at all lift heights, right from the driver's seat.

FEATURES

- OEM load backrest compatibility
- Excellent operator visibility
- No-weld installation
- Zinc plated, corrosion resistant components
- 5", 6" and 7" wide center mount fork carriers
- Center mount fork carriers

OPTIONS

- Bolt-on pallet protector/cylinder guard combinations
- Load backrests
- Bronze bearings
- Bronze lower hooks
- Radio Frequency (RF) Hydraulic Control
- Solenoid Valve Hydraulic Control
- Sequence Valve Hydraulic Control
- Non-Sideshifting (FP) units available



*An easy to install
fork positioner
that can handle
a variety of
challenging
applications.*

120K FORK POSITIONER

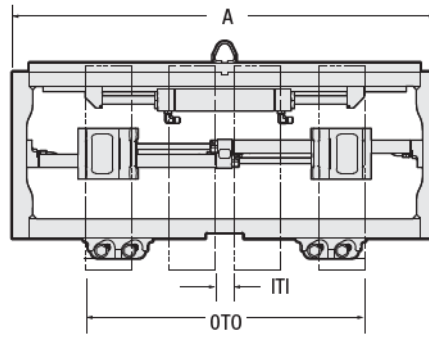
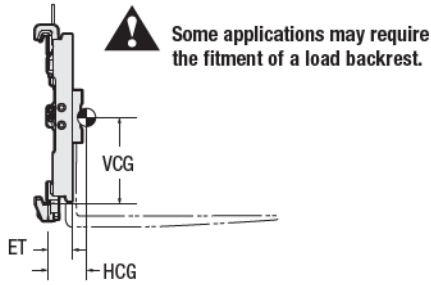

Sideshifting Fork Positioner

Catalog Order No.	Capacity @ 24" (600 mm) Load Center		Carriage Width w/o Load Backrest	Opening Range	Fork Pocket Width	Mtg. Class	Min. Truck Carriage Width	Weight		Effective Thickness	Horizontal Center of Gravity	Vertical Center of Gravity	Total Sideshift	Load Backrest Type
	lbs	kg						lbs	kg					
Cascade														
120K-FPS-C051	12000	5500	49.0"	3.8"-43.1"	7" ②	IV	41.9"	425	193	3.1"	1.8"	14.6"	8"	C
120K-FPS-C052	12000	5500	61.0"	3.8"-55.1"	7" ②	IV	50.9"	508	231	3.1"	1.8"	14.8"	8"	C
Caterpillar														
120K-FPS-C125 ①	12,000	5,500	44.3"	3.8"-38.3"	7" ②	IV	41.9"	411	187	3.1"	1.6"	14.6"	8"	B
120K-FPS-C122	12,000	5,500	46.9"	3.8"-40.9"	7" ②	IV	41.9"	422	192	3.1"	1.8"	14.6"	8"	A
120K-FPS-C127 ①	12,000	5,500	46.9"	3.8"-40.9"	7" ②	IV	41.9"	422	192	3.1"	1.8"	14.6"	8"	A
120K-FPS-C128 ①	12,000	5,500	59.1"	3.8"-53.1"	7" ②	IV	50.9"	493	224	3.1"	1.8"	14.8"	8"	A
120K-FPS-C123	12,000	5,500	59.1"	3.8"-53.1"	7" ②	IV	50.9"	493	224	3.1"	1.6"	14.8"	8"	A
120K-FPS-C126	12,000	5,500	60.0"	3.8"-54.1"	7" ②	IV	50.9"	504	229	3.1"	1.8"	14.8"	8"	B
Clark														
120K-FPS-C001	12000	5500	49.0"	3.8"-43.1"	7" ②	IV	41.9"	425	193	3.1"	1.8"	14.6"	8"	A
Hamech														
120K-FPS-C067	12,000	5,500	46.8"	3.8"-40.9"	7" ②	IV	41.9"	422	192	3.1"	1.8"	14.6"	8"	A
Hyundai														
120K-FPS-C061	12000	5500	55.0"	3.8"-49.1"	7"	IV	50.9"	482	219	3.1"	1.6"	14.8"	8"	A
Hyster														
120K-FPS-C021	12,000	5,500	42.0"	3.8"-36.1"	7" ②	IV	41.9"	400	182	3.1"	1.6"	14.8"	8"	B
120K-FPS-C018	12,000	5,500	47.2"	3.8"-41.3"	7" ②	IV	41.9"	425	193	3.1"	1.8"	14.6"	8"	B
120K-FPS-C022	12,000	5,500	48.0"	3.8"-42.0"	7" ②	IV	41.9"	427	194	3.1"	1.8"	14.6"	8"	B
120K-FPS-C023	12,000	5,500	54.0"	3.8"-48.1"	7" ②	IV	50.9"	477	217	3.1"	1.6"	14.8"	8"	B
120K-FPS-C024	12,000	5,500	60.0"	3.8"-54.1"	7" ②	IV	50.9"	504	229	3.1"	1.8"	14.8"	8"	B
Komatsu														
120K-FPS-C067	12,000	5,500	46.8"	3.8"-40.9"	7" ②	IV	41.9"	422	192	3.1"	1.8"	14.6"	8"	A
Mitsubishi														
120K-FPS-C125 ①	12,000	5,500	44.3"	3.8"-38.3"	7" ②	IV	41.9"	411	187	3.1"	1.6"	14.6"	8"	B
120K-FPS-C127 ①	12,000	5,500	46.9"	3.8"-40.9"	7" ②	IV	41.9"	422	192	3.1"	1.8"	14.6"	8"	A
120K-FPS-C122	12,000	5,500	46.9"	3.8"-40.9"	7" ②	IV	41.9"	422	192	3.1"	1.8"	14.6"	8"	A
120K-FPS-C123	12,000	5,500	59.1"	3.8"-53.1"	7" ②	IV	50.9"	493	224	3.1"	1.6"	14.8"	8"	A
120K-FPS-C128 ①	12,000	5,500	59.1"	3.8"-53.1"	7" ②	IV	50.9"	493	224	3.1"	1.8"	14.8"	8"	A
120K-FPS-C126	12,000	5,500	60.0"	3.8"-54.1"	7" ②	IV	50.9"	504	229	3.1"	1.8"	14.8"	8"	A
TCM														
120K-FPS-C082 ①	12000	5500	51.2"	3.8"-45.2"	7" ②	IV	50.9"	460	209	3.1"	1.6"	15.0"	8"	A
Toyota														
120K-FPS-C032	12000	5500	46.1"	3.8"-40.1"	7" ②	IV	41.9"	418	190	3.1"	1.6"	14.6"	8"	A
120K-FPS-C033 ①	12000	5500	46.1"	3.8"-40.1"	7" ②	IV	41.9"	418	190	3.1"	1.6"	14.6"	8"	A
Tusk														
120K-FPS-C067	12,000	5,500	46.8"	3.8"-40.9"	7" ②	IV	41.9"	422	192	3.1"	1.8"	14.6"	8"	A
Yale														
120K-FPS-C021	12,000	5,500	42.0"	3.8"-36.1"	7" ②	IV	41.9"	400	182	3.1"	1.6"	14.8"	8"	B
120K-FPS-C018	12,000	5,500	47.3"	3.8"-41.3"	7" ②	IV	41.9"	425	193	3.1"	1.8"	14.6"	8"	B
120K-FPS-C022	12,000	5,500	48.0"	3.8"-42.0"	7" ②	IV	41.9"	427	194	3.1"	1.8"	14.6"	8"	B
120K-FPS-C026	12,000	5,500	48.0"	3.8"-42.0"	7" ②	IV	41.9"	427	194	3.1"	1.8"	14.6"	8"	A
120K-FPS-C027	12,000	5,500	54.0"	3.8"-48.1"	7" ②	IV	50.9"	477	217	3.1"	1.6"	14.8"	8"	A
120K-FPS-C028	12,000	5,500	60.0"	3.8"-54.1"	7" ②	IV	50.9"	504	229	3.1"	1.8"	14.8"	8"	A

① Compatible with current OEM production.

② Adjustable to 5" and 6" wide forks. Add 4.3" and 2.3" to minimum opening range respectively.

▶ Load Backrest Types:

- A: End hole patterns
- B: Face hole patterns
- C: Face hole patterns with counterbore

▶ For availability of Truck specific Installation Kits contact Cascade or submit OEM Truck Model and Mast Type when ordering.

▶ Forks are not included with attachment.

▶ Overall Width, A dimension, is limited to 61.0" on 120/150K/165K Series.

▶ 60" fork maximum length.

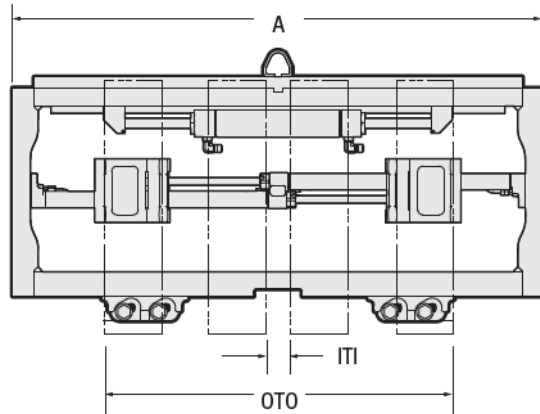
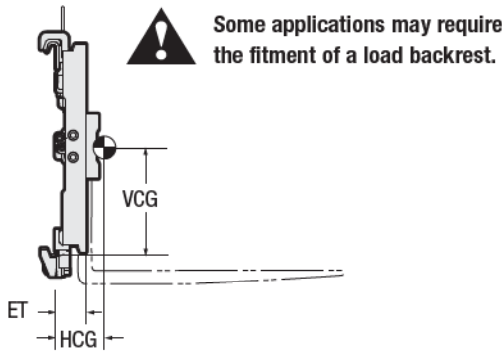

Sideshifting Fork Positioner

Catalog Order No.	Capacity @ 24" (600 mm) Load Center		Carriage Width w/o Load Backrest	Opening Range	Fork Pocket Width	Mtg. Class	Min. Truck Carriage Width	Weight		Effective Thickness	Horizontal Center of Gravity	Vertical Center of Gravity	Total Sideshift	Load Backrest Type
	lbs	kg						lbs	kg					
Cascade														
150K-FPS-C051	15000	7000	49.0"	3.8"-43.1"	7" ②	IV	46.0"	447	203	3.1"	1.6"	14.8"	12"	C
150K-FPS-C053	15000	7000	61.0"	3.8"-55.1"	7" ②	IV	48.0"	557	253	3.1"	1.8"	14.0"	12"	C
Caterpillar														
150K-FPS-C035	15,000	7,000	44.3"	3.8"-38.3"	7" ②	IV	41.9"	398	181	3.1"	1.6"	14.8"	12"	B
150K-FPS-C017	15,000	7,000	46.9"	3.8"-40.9"	7" ②	IV	46.0"	429	195	3.1"	1.6"	15.0"	12"	A
150K-FPS-C031	15,000	7,000	47.8"	3.8"-41.9"	7" ②	IV	46.0"	433	197	3.1"	1.6"	15.0"	12"	B
150K-FPS-C110 ①	15,000	7,000	51.0"	3.8"-45.1"	7" ②	IV	46.0"	453	206	3.1"	1.8"	15.2"	12"	B
150K-FPS-C108	15,000	7,000	59.1"	3.8"-53.1"	7" ②	IV	48.0"	548	249	3.1"	1.8"	14.0"	12"	A
Clark														
150K-FPS-C062 ①	15000	7000	55.0"	3.8"-49.1"	7" ②	IV	46.0"	526	239	3.1"	1.6"	14.2"	12"	A
Hamech														
150K-FPS-C075	15,000	7,000	59.4"	3.8"-53.5"	7" ②	IV	48.0"	550	250	3.1"	1.8"	14.0"	12"	A
Hyster														
150K-FPS-C025 ①	15,000	7,000	42.0"	3.8"-36.1"	7" ②	IV	41.9"	396	180	3.1"	1.6"	14.8"	12"	C
150K-FPS-C001	15,000	7,000	42.0"	3.8"-36.1"	7" ②	IV	41.9"	396	180	3.1"	1.6"	14.8"	12"	B
150K-FPS-C024 ①	15,000	7,000	48.0"	3.8"-42.0"	7" ②	IV	46.0"	433	197	3.1"	1.6"	15.0"	12"	C
150K-FPS-C002	15,000	7,000	48.0"	3.8"-42.0"	7" ②	IV	46.0"	433	197	3.1"	1.6"	15.0"	12"	B
150K-FPS-C026 ①	15,000	7,000	60.0"	3.8"-54.1"	7" ②	IV	48.0"	552	251	3.1"	1.8"	14.0"	12"	C
150K-FPS-C003	15,000	7,000	60.0"	3.8"-54.1"	7" ②	IV	48.0"	552	251	3.1"	1.8"	14.0"	12"	B
Mitsubishi														
150K-FPS-C017	15,000	6,810	46.9"	3.8"-40.9"	7" ②	IV	46.0"	429	195	3.1"	1.6"	15.0"	12"	A
150K-FPS-C110 ①	15,000	6,810	51.0"	3.8"-45.1"	7" ②	IV	46.0"	453	206	3.1"	1.8"	15.2"	12"	B
150K-FPS-C108	15,000	6,810	59.1"	3.8"-53.1"	7" ②	IV	48.0"	548	249	3.1"	1.8"	14.0"	12"	A
Nissan														
150K-FPS-C071	15000	7000	59.0"	3.8"-53.1"	7" ②	IV	48.0"	548	249	3.1"	1.8"	14.0"	12"	A
Toyota														
150K-FPS-C086	15000	7000	46.1"	3.8"-40.1"	7" ②	IV	46.0"	425	193	3.1"	1.6"	15.0"	12"	A
150K-FPS-C087 ①	15000	7000	46.1"	3.8"-40.1"	7" ②	IV	46.0"	425	193	3.1"	1.6"	15.0"	12"	A
Yale														
150K-FPS-C025 ①	15,000	7,000	42.0"	3.8"-36.1"	7" ②	IV	41.9"	396	180	3.1"	1.6"	14.8"	12"	C
150K-FPS-C024 ①	15,000	7,000	48.0"	3.8"-42.0"	7" ②	IV	46.0"	433	197	3.1"	1.6"	15.0"	12"	C
150K-FPS-C002	15,000	7,000	48.0"	3.8"-42.0"	7" ②	IV	46.0"	433	197	3.1"	1.6"	15.0"	12"	B
150K-FPS-C026 ①	15,000	7,000	60.0"	3.8"-54.1"	7" ②	IV	48.0"	552	251	3.1"	1.8"	14.0"	12"	C
150K-FPS-C043	15,000	7,000	60.0"	3.8"-54.1"	7" ②	IV	48.0"	552	251	3.1"	1.8"	14.0"	12"	A

① Compatible with current OEM production.

② Adjustable to 5" and 6" wide forks. Add 4.3" and 2.3" to minimum opening range respectively.

- ▶ Load Backrest Types:
 - A: End hole patterns
 - B: Face hole patterns
 - C: Face hole patterns with counterbore

▶ For availability of Truck specific Installation Kits contact Cascade or submit OEM Truck Model and Mast Type when ordering.

▶ Forks are not included with attachment.

▶ Overall Width, A dimension, is limited to 61.0" on 120/150K/165K Series.

▶ 60" fork maximum length.

165K FORK POSITIONER

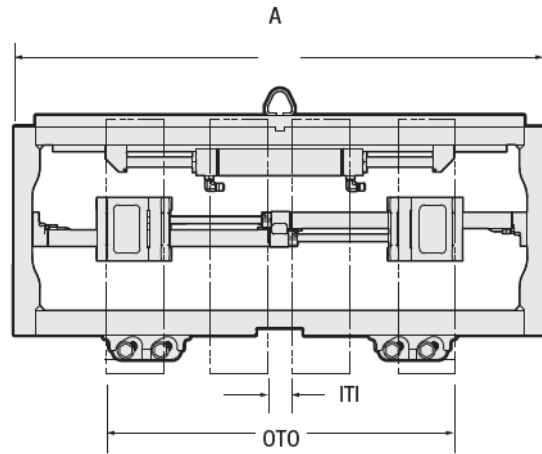
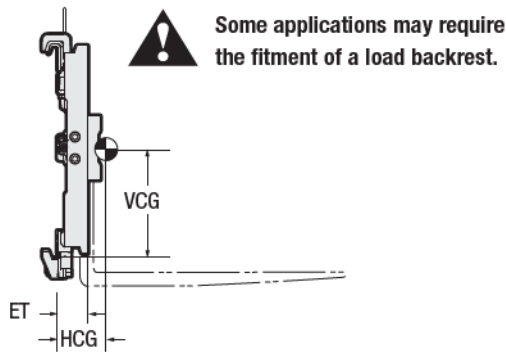

Sideshifting Fork Positioner

Catalog Order No.	Capacity @ 24" (600 mm) Load Center		Carriage Width w/o Load Backrest	Opening Range	Fork Pocket Width	Mt g. Class	Min. Truck Carriage Width	Weight		Effective Thickness	Horizontal Center of Gravity	Vertical Center of Gravity	Total Sideshift	Load Backrest Type
	lbs	kg						lbs	kg					
Cascade														
165K-FPS-C051	16,500	7,500	49.0"	3.8"-43.1"	7" ①	IV	46.0"	484	220	3.1"	1.8"	14.0"	12"	C
165K-FPS-C053	16,500	7,500	61.0"	3.8"-55.1"	7" ①	IV	55.1"	565	257	3.1"	1.6"	14.2"	12"	C

① Adjustable to 5" and 6" wide forks. Add 4.3" and 2.3" to minimum opening range respectively.

- ▶ Load Backrest Types: C: Face hole patterns with counterbore
- ▶ For availability of Truck specific Installation Kits contact Cascade or submit OEM Truck Model and Mast Type when ordering.
- ▶ Forks are not included with attachment.
- ▶ Overall Width, A dimension, is limited to 61.0" on 120/150K/165K Series.
- ▶ 60" fork maximum length.

INSTALLATION KIT

	Catalog Order No.
Single Function, JIC #6	6067030
Single Function, ORFS #6	6090492
Dual Function, JIC #6	6053309
Dual Function, ORFS #6	6099639

HYDRAULIC FLOW & PRESSURE

Maximum Pressure	Number of Functions	Min-Rec-Max Function 1	Min-Rec-Max Function 2
3,500 psi / 241 bar	2	1 - 4 - 5	1 - 4 - 5

HYDRAULIC FUNCTIONS

Hydraulic Functions	Truck Aux. Valves Required
2	2