



Precise positioning. Without leaving the seat.

APPLICATIONS

Manually moving forks is time consuming and strenuous. The C-Series Fork Positioner can cut load handling cycle time and reduce damage to pallets by providing fast, accurate fork positioning.

FEATURES

- Easy installation—forks included
- Positive fork positioning
- Heavy duty forks are double shaft mounted and slide on heavy duty bushings
- Cylinders, shafts and bushings are easily removed for servicing

OPTIONS

- Load backrests—36" & 48" high
- Integral fork sideshift
- Full frame sideshift
- 0" closing
- Pin mounting
- Independent arm control
- Integral mounting
- Special forks

*An efficient,
heavy duty Fork
Positioner for
general handling
applications.*

C-SERIES FORK POSITIONER

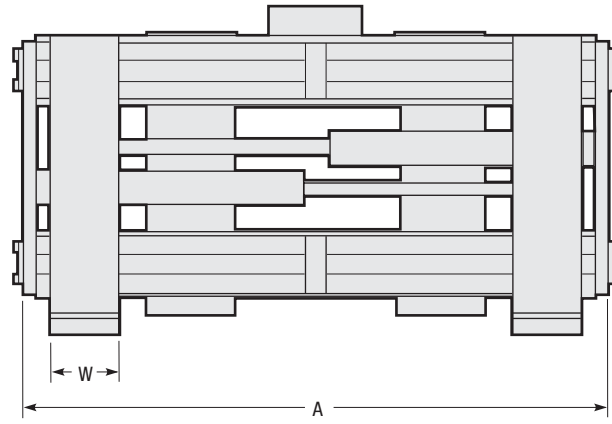
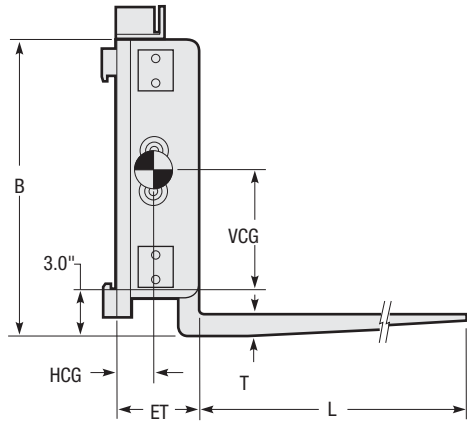

Capacity @ 24" (600 mm) Load Center		Fork Size ① L x W x T	Opening Range ITO	Catalog Order No.	Mtg. Class	Min. Truck Carriage Width	Weight		Effective Thickness ET	Horizontal Ctr. of Gravity HCG	Vertical Ctr. of Gravity VCG	Frame Width A	Overall Height B
lbs	kg						lbs	kg					
5,500	2,495	42" x 5" x 1.75"	2"-33"	55C-FPB-A001	II	30"	550	250	6.9"	11.0"	9.8"	36.75"	22.5"
5,500	2,495	42" x 5" x 1.75"	2"-39"	55C-FPB-A002	II	30"	600	272	6.9"	10.7"	10.0"	42.75"	22.5"
5,500	2,495	42" x 5" x 1.75"	2"-45"	55C-FPB-A003	II	30"	650	295	6.9"	10.5"	10.2"	48.75"	22.5"
10,000	4,540	42" x 6" x 2.00"	2.75"-38"	100C-FPB-B001	III	36"	970	440	7.4"	10.4"	12.7"	42.75"	28.5"
10,000	4,540	42" x 6" x 2.00"	2.75"-44"	100C-FPB-B002	III	36"	995	452	7.4"	10.2"	12.8"	48.75"	28.5"
10,000	4,540	42" x 6" x 2.00"	2.75"-56"	100C-FPB-B003	III	36"	1,050	477	7.4"	9.8"	12.9"	60.75"	28.5"
12,000	5,450	48" x 6" x 2.25"	2.75"-44"	120C-FPB-C001	IV	36"	1,330	604	8.5"	9.9"	12.0"	48.75"	31.5"
12,000	5,450	48" x 6" x 2.25"	2.75"-50"	120C-FPB-C002	IV	42"	1,360	617	8.5"	9.2"	12.2"	54.75"	31.5"
12,000	5,450	48" x 6" x 2.25"	2.75"-56"	120C-FPB-C003	IV	42"	1,400	636	8.5"	9.6"	12.3"	60.75"	31.5"
15,000	6,810	48" x 6" x 2.50"	2.75"-44"	150C-FPB-C001	IV	36"	1,430	649	8.75"	11.6"	13.6"	48.75"	31.5"
15,000	6,810	48" x 6" x 2.50"	2.75"-50"	150C-FPB-C002	IV	42"	1,460	663	8.75"	11.4"	13.7"	54.75"	31.5"
15,000	6,810	48" x 6" x 2.50"	2.75"-56"	150C-FPB-C003	IV	42"	1,500	681	8.75"	11.2"	13.8"	60.75"	31.5"
15,000	6,810	48" x 6" x 2.50"	2.75"-68"	150C-FPB-C004	IV	44"	1,650	749	8.75"	10.8"	14.1"	72.75"	31.5"

① Additional fork sizes available.

① Additional fork sizes available.

INSTALLATION KIT

Catalog Order No.
659245

HYDRAULIC FLOW & PRESSURE

Model	Minimum	Recommended	Max.	Max. Pressure
55C, 100C, 120C, 150C	5 GPM	7 GPM	10 GPM	2,300 PSI

MOUNTING CLASS INFORMATION

Mounting Class	Truck Capacity
II	2,000-5,500 lbs.
III	6,000-10,000 lbs.
IV	10,001-17,500 lbs.

HYDRAULIC FUNCTIONS

Models	Hydraulic Functions	Truck Auxiliary Valves Required
FPS	2	2
FPB	1	1

FORKS

Models	Fork Length	Catalog Order No.
55C	36"	F5536
55C	42"	F5542
55C	48"	F5548
55C	60"	F5560
100C	42"	F1042
100C	48"	F1048
100C	54"	F1054
100C	60"	F1060
120C	42"	F1242
120C	48"	F1248
120C	54"	F1254
120C	60"	F1260
120C	72"	F1272
150C	42"	F1542
150C	48"	F1548
150C	54"	F1554
150C	60"	F1560
150C	72"	F1572