

Shaft Type Forks Questionnaire



Shaft Type Forks

REQUESTOR INFORMATION :

Name _____
Company Name _____

Tel No _____
Fax No _____

SHAFT TYPE FORKS

- A _____ TO CENTERLINE OF TUBE
- B _____ INSERT
- C _____ OFFSET
- D _____ THICKNESS
- E _____ WIDTH
- F _____ LENGTH
- G _____ INLINE
- OD _____ OUTSIDE DIAMETER
- ID _____ INSIDE DIAMETER
- SD _____ SHAFT DIAMETER

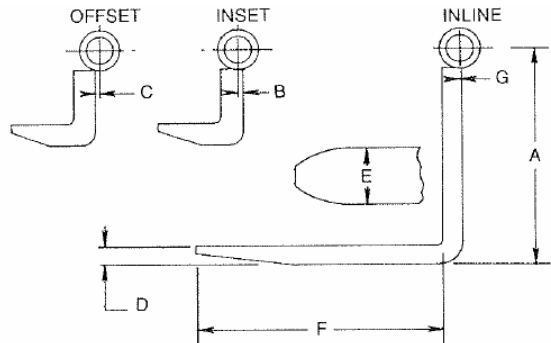

CLEARANCE MUST EXIST BETWEEN SHAFT AND TUBE ID

TIPS (TICK YOUR CHOICE)



NO. 1



NO. 2



NO. 3



NO. 4

TAPERS (TICK YOUR CHOICE)



STANDARD TAPER



FULL TAPER



FULL TAPER & POLISH

TUBE SPECIFICATIONS

NOTE: IF THERE IS NO SLOT IN TUBE, ONLY DIMENSION OF LENGTH IS REQUIRED

- H _____ ANGLE OF SLOT
- I _____ DEPTH OF SLOT
- J _____ LOCATION OF SLOT
- K _____ SLOT WIDTH
- L _____ TUBE LENGTH

